

Portable Equipment

High-Pressure Heavy-Duty Grease Pumps

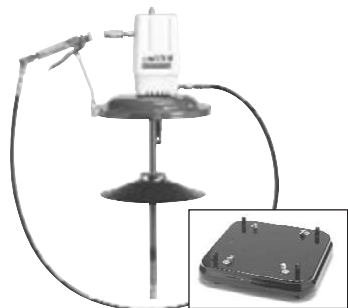

917

Series 20 • 50:1 • Air-Operated • Double Acting

The following models contain Lincoln's high-pressure Series 20 grease pumps.

Model 917 120 lb. Drum

Will dispense 45 ounces or 80 cubic inches of NLGI 0-2 grease per minute at 150 psi. Assures positive prime at lowest temperature. Drum cover 46007 finished in Lincoln red; roll-a-round base 80895 base in black; air motor cover in white. Height 43¹/₈". Base 17" square. Drum not included.

Model 917-57 120 lb. Drum

Same as 917 without roll-a-round base.

Model 346P 120 lb. Drum

Same as 917 except with 674 hand truck which provides convenient transportation for unit. Hand truck has two semi-pneumatic disc wheels and screw-type clamp which locks unit to truck. Drum not included.



346P

Model 987 25-50 lb. Pail/60 lb. Bulk

For 25-30 lb. refinery containers or 60 lb. bulk. Gasket and air vent in lid assembly makes unit completely dust-proof, leak-proof and spill-proof. Ideal for use in all types of weather; container rust-proofed and finished in Lincoln red. Height 31³/₄"; inside diameter of container 12¹/₂".



987

Model 989 25-50 lb. Drum

Steel cover has three thumb screws to clamp securely to any original 25-50 lb. refinery container. Carrying handle provides easy portability. Follower plate assures positive prime at lowest temperatures. Cover rust-proofed and finished in Lincoln red. Bucket not included.

Follower Plates

Model 84775

Deluxe universal follower for use with 25-50 lb. containers for 1", 1¹/₄", 1¹/₂" diameter pump tubes. All rubber unit ensures complete grease dispensing to the bottom of dented or plastic lined drums; wipes pail or drum clean. Metal cap holds insert firmly in place, ensuring seal and maintaining vacuum.

Model 84780

Same as 84775 except for use with 120 lb. containers for 1", 1¹/₄", 2¹/₈" diameter pump tubes. Used with Series 20 and 40 air-operated grease pumps.



989



84775

Heavy-Duty Portable Grease Pump Assemblies

Model	Bare	Drum Cover	Base	Delivery Kit	Follower Plate	Drum Size
917	82050	46007	80895	*	84780	120 lb.
917-57	82050	46007	NA	*	84780	120 lb.
346P	82050	46007	674	*	84780	120 lb.
987	83513	90656	NA	*	not supplied**	25-50 lb.
989	82716	91499	NA	*	84775	25-50 lb.

*Delivery kits for all units include: 75084 high-pressure hose, 11659 nipple, 740 control valve, 815 air coupler, 82399 straight swivel and 81387 universal swivel.

**Follower plate recommended to assure positive prime at lowest temperatures. Must be ordered separately. See page 8 for details.

Manual Bucket Pumps

These quality-built Lincoln bucket pumps dispense high-pressure lubrication in any weather—even at 0°F. Select from pump units developing 2500 to 5000 psi for normal lubrication service or lubrication of trac-roll bearings.

Model 1292 Grease Pump

Unit clamps on any 25-50 lb. refinery container in 60 seconds. Dimensions: 21 1/2" h. x 12 1/4" w. Tube size 1 1/4".

Model 1272

Large 30 lb. lubricant capacity with easy pumping action, develops a 3500 lb. maximum pressure to lubricate the most closely fitted bearings. Automatic pressure release prevents nozzle drippage, waste and mess. Pump and lid assembly easily removed as a single unit for filling. Order 7' hose and coupler assembly (81768) separately. Dimensions: 28" h x 14" w x 9" dia.

NOTE: Models 1272 and 81768 make up former model 1273D.

Model 1275

All purpose pump dispenses both lubricants and greases. Especially useful for lubrication of trac-roller bearings. Handle slot pin switches for high pressure 5000 psi or low pressure 2000 psi delivery. 40 lb. capacity steel container filled through pivot cover opening in lid. May also be used for fast, clean refilling of transmissions, differentials, gear cases and final drives. Order 5' hose (79060) and coupler (80933) separately. Dimensions: 23 1/2" h x 11 3/8" w x 14 5/8" long.

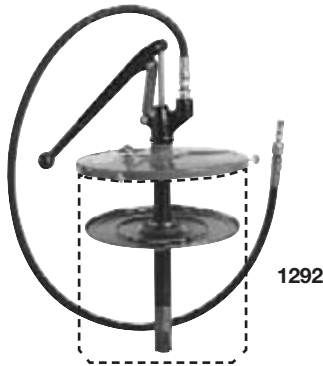

1292



1272
shown with
optional hose



1275
shown with
optional
hose and
coupler
assembly

WARNING

For safe and proper use, always consult instructions accompanying product.

Manual Grease Pumps

Model	Cont. Size	Max. Pressure	Coupler Acces.	Hose	Follower	Output
FOR USE WITH ORIGINAL REFINERY CONTAINERS—SUPPLIED W/BUCKET COVER ASSEMBLY						
1292	25-50 lb.	2500 psi	5852	5 ft. 79060	91695	.303/stroke ¹
SELF-CONTAINED MODELS						
1275	40 lb. bulk	5000 psi	80933	none	not supplied	.37 oz. stroke high ²
1272	30 lb. bulk	3500 psi	81768			.95 oz. stroke low

Filler Pumps—Portable & Stationary

- Fast (less than a minute), positive gun refilling with simple pumping action
- Filler socket assembly eliminates mess, waste and air pockets

Model 1296 Clamp-On Carry

Clamps to any original 25-50 lb. refinery container. Handles medium and light lubricants in any weather. Includes pump, filler socket, follower plate and ribbed steel drum cover. Rust resistant. Tube size 1 1/2".

Model 500 Stationary 120 lb. Drum

For use with original refinery drums with maximum head diameter of 14 9/16" and overall height of 26 5/8". Handles all high-pressure lubricants. Includes pump, filler socket and drum cover with one set of adjusting screws to accommodate variations in drum diameter. Red enamel finish; pump head and handle in black. Delivers 1 oz. per stroke.

Filler pumps

Model	Container Size	Follower Plate	Filler Socket**	Dimensions
1296	25-50 lb.	91393	82614	20" h x 12 1/4" w
500	120 lb.	none*	80133	26 5/8" h x 14 9/16" dia.

* For pumping extra heavy lubricants, order follower plate 84780 for 500 pump.

**Requires 91108 filler nipple



1296

500

Value Series 40:1 Single Acting Grease Pumps

Features and Benefits

- Professional quality lubrication at an affordable price
- High-pressure
- Portable medium- to light-duty chassis lubrication
- Proven valved piston design
- Simple grease plunger/bushing
- Control valve and universal swivel
- Easy, one-hand operation
- Built for durability and reliability



Model 4417 for 120 lb. Drums

Includes 40:1 value series pump, drum cover, high-pressure control valve, universal swivel, coupler, 7' connecting hose, follower plate and band dolly.

Model 4459 for 25-50 lb. Pail

Includes 40:1 value series pump, pail cover, handle, high-pressure control valve, universal swivel, coupler, 7' connecting hose, follower plate and band dolly.

Model 4489 for 25-50 lb. Pail

Same as 4459 except without band dolly.



Pump Models

	Model 4417	Model 4459	Model 4489
Container Size	120 lb.	25-50 lb.	
Four Wheel Caster Dolly	Yes		No
Delivery Kit	High-Pressure Grease Control Valve and Coupler, Universal Swivel, 7' Connecting Hose		
Ratio	40:1		
Air Motor Effective Diameter	2" / 52 mm		
Air Inlet Connection	1/4" NPTF (female)		
Lube Outlet	SAE-6 O-Ring Port		
Volume Output/Minute	5 in ³ / 82 cm ³		
Maximum Air Pressure	150 psi / 10.34 bar		
Minimum Air Pressure	40 psi / 2.75 bar		
Maximum Grease Output Pressure	6000 psi / 413 bar		
Flexible Follower	Included with all models		

Recommended Accessories

Air Line controls are a must for safe and effective pump operation.



Model No.	Description
815	1/4" Air Coupler
11659	1/4" Air Nipple
602003	1/4" Miniature Air Regulator
247843	Air Line Pressure Gauge
10462	1/4" Pipe Nipple for Regulator attachment

Portable Equipment

High-Pressure Grease Pump Accessories

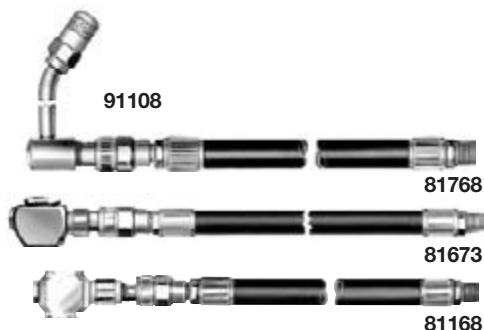

Delivery Hose Assemblies for Bucket Pumps

2250 psi maximum operating pressure

Model	Length	Swivel	Coupler Extension
FOR CONTACTING HYDRAULIC FITTINGS			
81768	7'	80924	5834
FOR CONTACTING STANDARD BUTTON-HEAD FITTINGS			
81673	7'	80924	81458
FOR CONTACTING LARGE BUTTON-HEAD FITTINGS			
81168	7'	80924	80933



Model 80133 Filler Socket Assembly

Convert guns and pumps for fast, convenient, economical loading. For attaching filler pumps other than Lincoln models; 3/8" NPT(f).

Drum Covers

Model 46007

Drum cover for 120 lb. or 16-gallon open top refinery containers for all series 20, 25 and 40 pumps.

Model 81523

Drum cover for 400 lb. or 55-gallon open top refinery containers for all series 20, 25 and 40 pumps.

Drum Dollies

Model 84191 25-50 lb. Band Dolly

Band-type dolly for any original 25-50 lb. refinery containers; caster 66060.

Model 84192 120 lb. Band Dolly

Band-type dolly for use with 120 lb. refinery containers; caster 66060.

Model 84377 Drum Dolly

Use with any 400 lb. drum. ID 23 1/4", height 5 1/4", hard rubber wheels: 1" wide, 2 1/2" dia.

Model 674 Hand Truck

All steel, rugged construction with 6" dia. wheels. Finished in Lincoln red. 41" high x 15" wide. For use with an 120 lb. or 16-gallon drum.

Model 80895 Roll-A-Round Base

Use with 120 lb. refinery containers. Four ball-bearing swivel casters and screw clamps.

Accessories

Model 66060 2 1/2" Caster for Roll-A-Round Base Units

Standard equipment on Lincoln drum and band dollies.

Model 84941

Eye bolt kit for all series 20, 25 and 40 pumps, makes drum changing easy. Two part kit screws directly onto pump for lifting with pump elevator.

Model 84942 Flange Mount Kit

For mounting Series 24 and 40 oil pumps to custom made tanks/lube trucks.

Model 80202 Volume Elbow

For use in stationary installations with high-pressure Lubriguns. 1/4" NPT(m) inlet; 1/4" NPT(f) outlet.





2535

Medium-Pressure • Gear Lube and ATF Air-Operated Mobile Gear Lube Dispensers

Fast, clean refilling using efficient Lincoln air-operated pumps.

- 3:1 (2435) and 5:1 (2535) pump ratios delivers gear oil with minimum consumption.
- Air expeller built into pump tube prevents air from registering through meter.
- Large replaceable swivel casters provide ease of maneuverability (mobile models).
- Baked on enamel finish retards rust and corrosion.
- Includes air coupler 815 and 780 shut-off valves. Drum not included.

Manual Gear Lube Dispensers

These quality manually operated pumps provide fast, clean refilling of differentials, gear cases and final drives.

- Cast iron pump outlet body and handle (except 1293) provide durability and longevity.
- Metered models have air expeller built into pump tube (prevents air from registering on meter).
- Large replaceable swivel casters provide ease of maneuverability (mobile models).
- Baked enamel finish helps prevent rust and corrosion.
- Self-contained units and sealed models prevent contamination or spillage of product being dispensed.
- Smooth, easy pumping action (no crank or gears) dispenses all types of gear lubricants, even in the coldest weather.

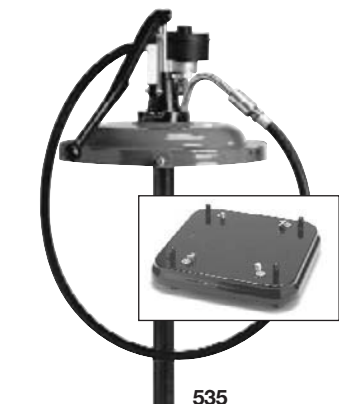

535

ATF Dispensers

Provides fast, clean refilling of all types of transmissions. Ideal for passenger vehicles, light trucks and vans.

- Cast iron pump outlet body and handle provide durability and longevity.
- Air expeller built into pump tube prevents air from registering through meter.
- Large replaceable swivel casters provide ease of maneuverability (mobile models).
- Baked-on enamel finish retards rust and corrosion.
- Smooth, easy pumping action for positive fluid dispensing, even in the coldest weather.



1253

WARNING

For safe and proper use of pumps, always consult instructions accompanying



1254

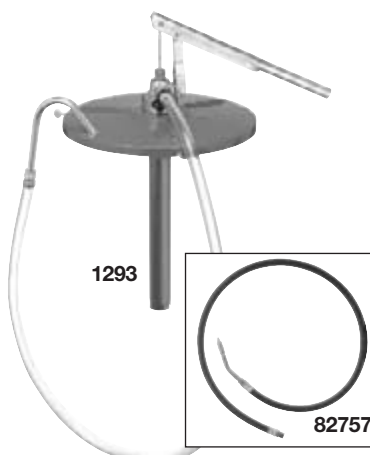

1293

82757



527

Portable Equipment

Medium-Pressure Fluid Pumps



Air-Operated Mobile Gear Lube Dispensers

Model	Container	Meters	Style	Base	Hose Length	Pump Tube	Nozzle	Output
2435	120 lb.	870 (pint)	Drum cover	80895 roll-a-round	5 ft. (73060)	25 ³ / ₄ "	780	6 gpm
2535	120 lb.	870 (pint)	Drum cover	80895 roll-a-round	5 ft. (73060)	25 ³ / ₄ "	780	6 gpm
2435LN	120 lb.	2873 (liter)	Drum cover	80895 roll-a-round	5 ft. (73060)	25 ³ / ₄ "	780	6 gpm

Manual Gear Lube Dispensers

535	120 lb.	(pints)	15" ID drum cover	80895 roll-a-round	5 ft. (74560)	25 ³ / ₄ "	80599	*
535LN	120 lb.	2873 (liters)	15" ID drum cover	80895 roll-a-round	5 ft. (74560)	25 ³ / ₄ "	80599	*
535-58	120 lb.	(pints)	15" ID drum cover	none	5 ft. (74560)	25 ³ / ₄ "	80599	*
549	120 lb.	none	15" ID drum cover	80895 roll-a-round	5 ft. (74560)	25 ³ / ₄ "	80599	*
549-58	120 lb.	none	15" ID drum cover	none	5 ft. (74560)	25 ³ / ₄ "	80599	*
1253	30 lb. bulk	(pints)	self cont. handle	Int. 9" dia / 13 ³ / ₄ " w	5 ft. (74560)	17" below rim	80599	*
1253LN	30 lb. bulk	2873 (liters)	self cont. handle	Int. 9" dia / 13 ³ / ₄ " w	5 ft. (74560)	17" below rim	80599	*
1254	30 lb. bulk	none	self cont. handle	Int. 9" dia / 13 ³ / ₄ " w	5 ft. (74560)	13" below rim	80599	*
1293	30 lb. bulk	none	12" ID clamp-on carry	none	5 ft. (74560)	13" below rim	80999	**

Model 82757 Hose/Nozzle Kit

Hose and nozzle upgrade kit for model 1293. Includes 80999 nozzle assembly and 5' 74560 hose. Order separately.

ATF Dispensers

527	120 lb.	none	15" ID drum cover	80895 roll-a-round	7 ft. (91265)	25 ³ / ₄ " below rim	93547	***
527A	120 lb.	(quarts)	15" ID drum cover	80895 roll-a-round	7 ft. (91265)	25 ³ / ₄ " below rim	93547	***

* 1 pt. per 7 strokes using SAE 90 Gear Lubricator at 70°F

** 1 oz. per stroke using SAE 90 at 70°F

*** 8 strokes per quart



Model 674 Hand Truck

All steel, rugged construction with 6" dia. wheels. Finished in Lincoln red. 41" high x 15" wide. For use with an 120 lb. or 16-gallon drum.

Model 80895 Roll-A-Round Base

Use with 120 lb. refinery containers. Four ball bearing swivel casters and screw clamps. Included with models listed above.

