



### Features

- State of the art, fully pneumatic Air Motors, 3–4–6–8 inches (76–101–152–203 mm) diameter.
- Full 6" stroke for greater output per cycle.
- Modular design for easy repair.
- Only 5 moving parts, no metal to metal contact.
- Newly designed pump tubes offer ratios and outputs to fit any application.
- Available to fit any drum or pail size.
- Offered in carbon steel, stainless steel or hard chrome plated.
- Complete selection of packing materials available.
- Full line of priming equipment and mounting devices.
- Ball style for fluid materials, shovel foot style for high viscosity non-fluid materials.

### Series III Air Motors

- Full pneumatic operation for longer life and durability—only five moving parts.
- Total modular design for ease of service and maintenance.
- Quiet operation—meets or exceeds OSHA requirements at all recommended operation air pressures.
- Interchangeable with all PowerMaster® III Pump Tubes.
- Acceptability of Pump Monitors and controls.



### AirBrake™

- Shuts down pump immediately when excessive pump cycle speed (runaway) occurs.
- Prevents pump damage due to a runaway condition.
- Indicates system fault caused by empty container or broken supply line.
- Limits spills due to pump outlet hose failure.
- Sends fault signal to remote alarm locations with optional 244398 signal kit.
- Can be ordered already installed (refer to Pump Specification Chart).
- Can be added later. Order Model 85317.
- Easy to install and set—graduated dial with detents
- Kit 273429 upgrades existing AirBrake-equipped pumps to the latest specifications



*See Pump Selection Chart in this section.*



Model 84985

### Pump Tubes—Ball Foot Design

- For light to medium viscosity, fluid materials.
- Available in 3 styles: stub length for bulk mounting, 55 gallon or 16 gallon drum size.
- Complete packing selection for total chemical compatibility.
- Ratios from 6:1—42:1, outputs to 3.9 gpm (14.6 lit/min.).
- Complete interchangeability with all Series III Air Motors.
- Exclusive, patented, “leakless” gland assembly kit is available as an accessory.



Model 84991

### Pump Tubes—Shovel Foot Design, Plunger and Bushing Style

- For medium to high viscosity, non-fluid materials.
- Available in 55 gallon or 16 gallon drum lengths, or mounts on pressure primer for very high viscosity materials.
- Full range of ratios: 12:1 through 84:1 for all applications.
- Selected fit, hardened steel plunger and bushing is particularly well suited to viscous lubricants.
- No washers, o-rings or packings to replace on pump piston for ease of maintenance.
- Shovel foot adds mechanical priming to normal suction, assures positive prime with the most viscous of lubricants.
- Complete interchangeability with all Series III Air Motors.
- Exclusive patented, leakless gland assembly kit (to protect gland seal—the only seal in pump tube) is available as an accessory.



Model 84976

### Pump Tubes—Shovel Foot Design, Packed Piston Style

- Furnished with exclusive, patented, leakless gland assembly.
- For medium to high viscosity, non-fluid materials.
- Available in 55 gallon or 16 gallon drum lengths; also suitable for mounting on priming equipment or standpipe mounting for bulk delivery.
- Full range of packing materials available for product compatibility.
- Complete interchangeability with all Series III Air Motors.
- Full range of ratios: 10:1 through 80:1.
- Specifically designed to enhance growing market for dispensing industrial type materials: sealants, adhesives, urethanes, inks, etc. . .

*See Pump Selection Chart in this section.*

# Industrial Pumping Equipment

## PowerMaster® III Pump Selection Chart



### Low to Medium Viscosity Pumps—Carbon Steel for Transfer of Non-Corrosive Materials

#### Ball Pumps

Ratio	Pump Model Std. Air Motor Only	Pump Tube Style	Air Motor Model	Diameter in. / mm	Pump Tube Model	Material Outlet N.P.T.F.	Output Per Cycle cu. in. / cc	Approximate Cycles per gal / liters
24:1	2021	55 gal	Std. 84806 w/ AirBrake *94906	6 / 152	84985	3/4"	11.9 / 195	20 / 5
12:1	2001	55 gal	Std. 84804 w/ AirBrake *94904	4 1/4 / 108	84985			
	2014	Stub			84986			
6:1	2052	55 gal	Std. 84803	3 / 76	84985			
	2051	Stub			84986			

#### Shovel Foot Pumps—Packed Piston

32:1	*2076	16 gal	Std. 84804 w/ AirBrake *94904	4 1/4 / 108	84979	3/4"	4.6 / 75	51 / 13
20:1	*2075	16 gal			84977		6.7 / 110	35 / 9
10:1	*2066	55 gal	Std. 84803	3 / 76	84976			

#### Shovel Foot Pumps—Plunger and Bushing

80:1	2023	55 gal	Std. 84806 w/ AirBrake *94906	6 / 152	84993	3/4"	3.7 / 61	63 / 16
75:1	2004	55 gal	Std. 84804 w/ AirBrake *94904	4 1/4 / 108	84997		2.1 / 34	111 / 29
	2008	16 gal			84998		3.0 / 49	78 / 20
50:1	2010	55 gal			84995			
	2011	16 gal			84996			
24:1	2002	55 gal			84991		6.1 / 100	38 / 10

\* Order pump tube and air motor separately for these models or when ordering AirBrake™ equipped models.

### Other PowerMaster Air Motor/Pump Tube Combinations (all feature 3/4" NPTF Material Outlet)

#### Carbon Steel Ball Type

Ratio	Pump Tube Style	Air Motor Model	Pump Tube Model	Max. GPM/LPM Free Delivery 70 CPM
42:1	55 gal	Std. 84808	84985	3.9 / 14.6
	16 gal	w/ AirBrake *94908	84984	
	Stub		84986	
24:1	16 gal	Std. 84806 w/ AirBrake *94906	84984	
	Stub		84986	
12:1	16 gal	Std. 84804 w/ AirBrake *94904	84984	
6:1	55 gal	Std. 84803	84985	
	Stub		84986	

#### Carbon Steel Shovel Type Plunger & Bushing

Ratio	Pump Tube Style	Air Motor Model	Pump Tube Model	Max. GPM/LPM Free Delivery 70 CPM
84:1	55 gal	Std. 84808 w/ AirBrake *94908	84991	2.0 / 7.5
	16 gal		84992	
80:1	16 gal	Std. 84806 w/ AirBrake *94906	84994	1.2 / 4.5
48:1	55 gal		84991	2.0 / 7.5
	16 gal	84992		
40:1	55 gal	Std. 84804 w/ AirBrake *94904	84993	1.2 / 4.5
	16 gal		84994	
24:1	16 gal		84992	2.0 / 7.5
36:1	55 gal	Std. 84803	84997	0.7 / 2.6
	16 gal		84998	
24:1	55gal		84995	1.0 / 3.7
	16 gal		84996	
20:1	55 gal		84993	1.2 / 4.5
	16 gal		84994	
12:1	55 gal	84991	2.0 / 7.5	
	16 gal	84992		

\* Order pump tube and air motor separately.

#### Carbon Steel Shovel Type Packed Piston

Ratio	Pump Tube Style	Air Motor Model	Pump Tube Model	Max. GPM/LPM Free Delivery 70 CPM
80:1	55 gal	Std. 84808 w/ AirBrake *94908	84976	2.2 / 8.2
	16 gal		84977	
64:1	55 gal	Std. 84806 w/ AirBrake *94906	84978	1.5 / 5.7
	16 gal		84979	
44:1	55 gal		84976	2.2 / 8.2
	16 gal		84977	
32:1	55 gal	Std. 84804 w/ AirBrake *94904	84978	1.5 / 5.7
22:1	55 gal		84976	2.2 / 8.2
15:1	55 gal	Std. 84803	84978	1.5 / 5.7
	16 gal		84979	
10:1	16 gal		84977	2.2 / 8.2

# Industrial Pumping Equipment

## PowerMaster® III Pump Selection Chart



### Ball Pumps

Gallons / Liters Per Minute			Minimum I.D. Air Supply Hose in. / mm	Air Consumption Per Cycle			
30 CPM	50 CPM	70 CPM		S.C.F.M. @ 70 psig	M <sup>3</sup> /Min. @ 4.8 bar	S.C.F.M. @ 100 psig	M <sup>3</sup> /Min. @ 6.8 bar
1.5 / 5.8	2.6 / 9.7	3.9 / 14.6	½" / 12	1.1	0.031	1.6	0.045
				0.8	0.023	1.1	0.031
			¾" / 10	0.5	0.014	0.7	0.02

### Shovel Foot Pumps—Packed Piston

0.6 / 2.3	1.0 / 3.8	1.5 / 5.7	½" / 12	0.8	0.023	1.1	0.031
0.9 / 3.3	1.5 / 5.5	2.2 / 8.2					
0.9 / 3.3	1.5 / 5.5	2.2 / 8.2	¾" / 10	0.5	0.014	0.7	0.02

### Shovel Foot Pumps—Plunger and Bushing

0.5 / 1.8	0.8 / 3.0	1.2 / 4.5	½" / 12	1.1	0.031	1.6	0.045
0.3 / 1.0	0.5 / 1.7	0.7 / 2.6		0.8	0.023	1.1	0.031
0.4 / 1.5	0.6 / 2.5	1.0 / 3.7					
0.8 / 3.0	1.3 / 5.0	2.0 / 7.5					

**Note:** Air motors and pump tubes shipped separately. Assembly required.

### Other PowerMaster Air Motor/Pump Tube Combinations (all feature ¾" NPTF Material Outlet)

#### Hardened Steel Ball Type

Ratio	Pump Tube Style	Air Motor Model	Pump Tube Model	Max. GPM / LPM Free Delivery 70 CPM
42:1	55 gal	84808 w/ AirBrake *94908	84983	3.9 / 14.6
24:1		84806 w/ AirBrake *94906		
12:1		84804 w/ AirBrake *94904		
6:1		84803		

#### Chrome Plated Ball Type

Ratio	Pump Tube Style	Air Motor Model	Pump Tube Model	Max. GPM / LPM Free Delivery 70 CPM
42:1	55 gal	84808 w/ AirBrake *94908	84982	3.9 / 14.6
24:1		84806 w/ AirBrake *94906		
12:1		84804 w/ AirBrake *94904		
6:1		84803		

#### Stainless Steel Ball Type

Ratio	Pump Tube Style	Air Motor Model	Pump Tube Model	Max. GPM / LPM Free Delivery 70 CPM
42:1	55 gal	84808 w/ AirBrake *94908	84981	3.9 / 14.6
	Stub		84987	
24:1	55 gal	84806 w/ AirBrake *94906	84981	
	Stub		84987	
12:1	55 gal	84804 w/ AirBrake *94904	84981	
	Stub		84987	
6:1	55 gal	84803	84981	
	Stub		84987	

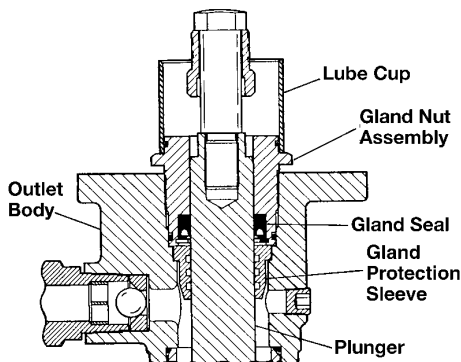

### Patented\* Leakless Gland Assembly

The gland seal of all reciprocating positive displacement pumps is its weakest point and is the single most common cause of pump failure, lost downtime and maintenance expense. Lincoln's new gland design uniquely addresses the causes for premature gland seal failure.

A special protective bushing (or sleeve) with concentric grooves creates a labyrinth path to reduce the internal operational pressure as well as the pressure fluctuations developed during pump stroke changeover.

Leakless Gland Assembly is standard with Packed Piston Pumps and is available for all PowerMaster III Pumps, as an accessory.

\* U.S. Patent No. 4,976,192



Model 86214

### Gland Protection Sleeves

Order Model	For Pump Tubes
86214	All Ball Foot Design Pump Tubes
86215	84997 & 84998
86216	84993 & 84994
86217	84995 & 84996
86218	84991 & 84992



Model 86213

### Model 86213 Lube Cup Kit

For all PowerMaster® III pump tubes. Used in conjunction with the gland protection sleeve to prolong service life of gland packing. Prevents material from drying out on plunger.

### Packing Kits for PowerMaster® III Pump Tubes

Lincoln offers alternate packing kits of Teflon® for some PowerMaster III Pump Tubes because many materials used in today's manufacturing environment may not be compatible with the standard seals. Please consult Lincoln for compatibility of the material to be dispensed with standard packings or alternate packing kits.

Teflon® is a registered trade mark of the Dupont Company.



Model 84502

Pump Tube	Teflon® Kit
84982	84502
84984	
84985	
84986	
84987	



Model 81412



Model 83166



Model 81538



Model 83369



Model 83132



Model 84963



Model 84826



Model 84945



Model 16177



Model 84377



Model 83727

### Drum Covers

#### Model 81412

Standard 55 gallon drum cover for mounting PowerMaster III series drum pumps on full open drums.

#### Model 83166

Special 55 gallon drum cover for mounting PowerMaster III series drum pumps on full open drums. Includes port for installation of material agitator.

#### Model 81538

Standard 16 gallon drum cover for mounting PowerMaster III series drum pumps on full open drums.

### Follower Plates

#### Model 83369

For 400 pound drums.

#### Model 84780

For 120 pound drums.

### Model 83132 Bung Bushing

This 55 gallon drum bung bushing screws into the bung opening of the drum to secure any Lincoln PowerMaster III Pump.

### Model 84963 Flange Mounting Assembly

Used for rigid mounting of PowerMaster III Pumps to the top of fabricated bulk tanks.

### Model 84826 Wall Mount Bracket Kit

For PowerMaster III Air Motor assemblies.

### Model 84945 Suction Kit

Used with PowerMaster III Stub Pumps for convenient transfer of petroleum products from drums, bulk tanks or reservoirs. Includes bung bushing suction tube, hose and coupling assembly and other hardware.

**Note:** 2"x1" bell reducer required—not included.

### Model 16177 Foot Valve Adapter

Converts inlet of Models 84984 and 84985 Ball Type PowerMaster III Pumps to 1½" NPTF female thread for attaching extension pipe.

### Drum Dollies

#### Model 84377

55 gallon (400 lbs) band-type drum dolly with four swivel casters and screw clamps.

#### Model 84192

16 gallon (120 lbs) band-type drum dolly with four swivel casters and screw clamps.

### Model 83727 Standpipe/Model 83732 Adapter Kit

Use of Model 83732 Adapter & Bracket Kit will enable PowerMaster III pumps to be assembled to Model 83727 Stand Pipe for pumping from bulk tanks. Inlet 3" NPT female.



### Elevator, Primer and Pressure Primers

Lincoln's mounting accessories include an elevator (Model 1709) to facilitate drum change-over by lifting the pump from an empty drum and lowering it into a new drum with minimum effort. Primers and Pressure Primers are available for positive priming of viscous materials which are forced into the pump inlet by the downward force of the follower. Models are available for most applications from five gallon pails to 55 gallon drums. Models include followers with O-ring seals (single O-rings for 5 gallon pail units and double O-rings for 55 gallon drum units) which seal the container of material from outside contamination and drying while wiping the container's sides clean.

Pressure Primers include a four-way valve which permits the air supply to be coupled to the unit at all times. Use of an air regulator and gauge is recommended. In order to prevent damage to pumps caused by operating after a drum is empty, a low level air cut-off assembly is recommended.



Model 1709



Model 2716



Model 1701



Model 1704

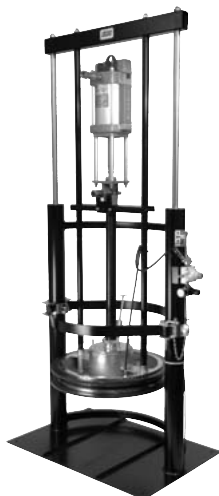

Model 1736

Model	For Drum Size Gal.	Description	Operating Air Pressure psi / bar	Priming Pressures PSI / Bar		Height		Base Dim. in. / mm
				@70 4.9	@100 7	Lowered in. / cm	Raised in. / cm	
1709	55	Single Post Elevator	50-200 3-14	NA	NA	73 185.4	112 284.5	NA Beam Length 19 / .5 360° Rotation
2716	55	Single Post Pump Hoist & Follower for low to med. viscosity materials 100K to 200K centipoise range	50-200 3-14	NA	NA	73 185.4	110½ 280.7	12½ x 14 317.5 x 355.5
1701**	5	Single Post for viscous material over 500K centipoise	30-150 3-10	4.4 .3	6.3 .44	42½ 108	50½ 128	22¼ x 22¼ 600 x 600
1704	55		40-100 3-7	5 .35	7.1 .5	89 226	89 226	26 x 26 700 x 700
1736	55	Twin Post for viscous materials in the 200K to 500K centipoise range	40-150 3-10	2.7 .2	3.7 .26	66½ 167.6	103 261.6	24 x 36 600 x 1000

**Notes:**

\*\*Model 83943 portability kit is available for Model 1701. Includes axle and wheels.

For Pressure Primers for 120 lb. drum pumps or for follower rings of materials other than standard Buna-N, contact Lincoln Technical Services.



**Low Level Air Cut-Off Assembly**

**Model 83811**

For use with Model 1704 Pressure Primer. Mounts directly to elevator support. Automatically shuts off air flow to pump when drum of material is emptied. Eliminates unnecessary parts wear caused by continuous pump action when drum is empty. Inlet 3/4" N.P.T.(F).

**Model 83970**

Same as Model 83811, except for use with Model 2716.

**Model 84143**

Same as Model 83811 except for use with Model 1736.

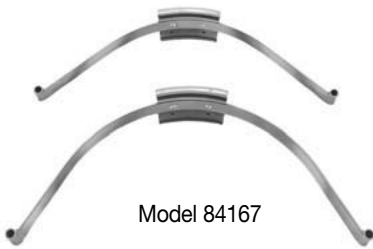

Model 84167

**Chimeless Drum Kits**

Because some materials are supplied in straight sided or chimeless drums, Lincoln has developed hold-down kits which facilitate follower and pump extraction from these drums. Kits are available as follows:

Kit No.	For Model
84167	1704
84503	1736



Model 85387-8  
 Included in 84144 Kit

**Airline Kits for Primer and Pressure Primers**

**Model 84144**

Includes filter-lubricator-regulator, bracket and fittings to adapt air accessories to models 2716, 1736 and 1704. Includes 1/2" controls.

**Model 84141**

Same as Model 84144, except includes 3/4" controls.



Model 84722

**Model 84722 Series III Air Motor Exhaust Adapter**

Replaces standard muffler. Converts exhaust port to 3/4" NPT female thread.



Model 84723

**Model 84723 Series III Air Motor Cover Panel Kit**

Metal cover fits over tie rods. Encloses moving plunger rod.