

Transfer Systems

Pump material from one container or reservoir to another. Typical applications involve high volume transfer of low to medium viscosity fluids.

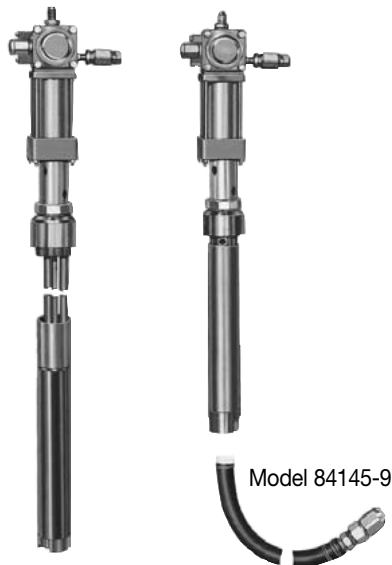

Model 84080-9

Model 84145-9

Model	Container Size	Ratio	Maximum Discharge Pressure psi / bar	Maximum Delivery GPM/ LPM	Pump Tube Construction	Packings	Pump Outlet
84080-9	55 gal.	3:1	375 / 26	2.5 / 9.5	316 Stainless Steel	Teflon®	½" NPTF
84145-9	Bulk						
82230*	16 gal. or 55 gal.	1:1	150 / 10	22 / 82	Carbon Steel	Leather	¾"-11-½" A.N.
84829	16 gal., 55 gal. or Bulk			16.5 / 66	Tube-Carbon Outlet Body Valox	Buna-N	¾" NPTF

* Accessories for 82230: 82715-Teflon® Kit; 91172-Hose & Nozzle²

Model	Special Features
84080-9	2" bung bushing and ¼" NPTF return inlet.
84145-9	Wall mount kit, and suction hose check. ¹
82230	Built-in air control valve for throttling air supply to pump to control material output. Operates on pressure as low as 20 psi (1.4 bar). Self adjusting bung bushing.
84829	Light weight and efficient. The pump will stall against pressure and can be controlled by a fluid dispensing valve.

Notes:

1. Suction hose or tube (not included) should be compatible with pumped product and not exceed 10' (3 m) long nor less than ¾" (19 mm) I.D.
2. 91172 transfer pump hose. 8 feet (2.5 m) ¾" (19 mm) I.D. standard hose and curved spout, with inlet threaded ¾" - 11 - ½" A.N. to fit outlet of 82230 pump.
3. For transfer systems involving long supply lines, PowerMaster III Stub Pumps are available. Consult Lincoln for your application needs.



Model 82230

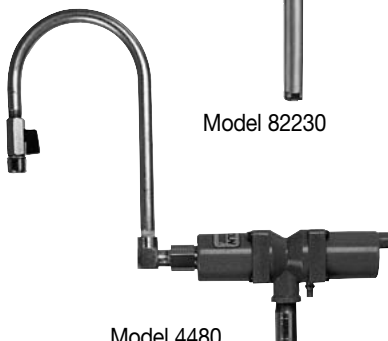

Model 4480

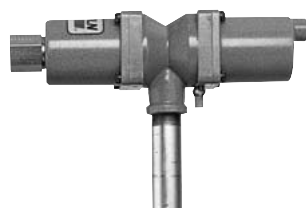

Model 4475

Model 4475 Series Pump

The Model 4475 pump is a reciprocating-piston, low-pressure single action pump. Air powers the pump's piston on the dispensing, or working, stroke. An internal spring returns the piston and resets it for the working stroke. It pumps continuously when the dispensing (fluid outlet) valve is open and 20-120 psig air is supplied to the pump.

Specifications

Model No.	Description	Material Outlet	Operation	Pump Tube Length	Attachment
4475	Bare Pump	½" NPTF	Pneumatic pressure delivery stroke, spring return stroke	34" (86 cm)	2" Bung, adjustable for 55 & 16 gal. drums, bench & portable tanks
4480	Spigot Pump	Spigot extension with on/off valve			

Model No.	Effective Pump Ratio	Inlet Air Pressure	Output/Stroke	Free Delivery
4475	Approx. 0.7:1 to 0.8:1 depending on inlet air pressure	Max: 120 psi (8.3 bar)	2.9 in ³	Up to 4 gpm (15 lpm)
4480		Min: 20 psig (1.4 bar)	(48 cm ³)	